

## Katalogové označení: 301

Koleno 90° závitové, 1.4401

Dimension inch	NW	L mm	D mm
1/8"	6	17,0	16,5
1/4"	8	19,0	20,0
3/8"	10	22,5	23,5
1/2"	15	26,0	27,0
3/4"	20	32,0	33,0
1"	25	36,0	40,0
1 1/4"	32	42,0	49,0
1 1/2"	40	46,5	55,0
2"	50	55,5	67,0
2 1/2"	65	68,0	81,0
3"	80	77,0	98,0
4"	100	93,0	124,0

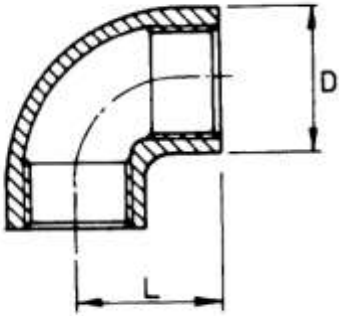

## Katalogové označení: 302

Kříž závitový, 1.4401

Dimension inch	NW	L mm	D mm
1/8"	6	34,0	15,5
1/4"	8	38,0	18,0
3/8"	10	46,0	23,5
1/2"	15	54,0	27,0
3/4"	20	64,0	33,0
1"	25	71,5	40,0
1 1/4"	32	85,0	49,5
1 1/2"	40	96,0	55,5
2"	50	112,0	68,0
2 1/2"	65	138,0	90,0
3"	80	154,0	108,5
4"	100	187,0	124,0

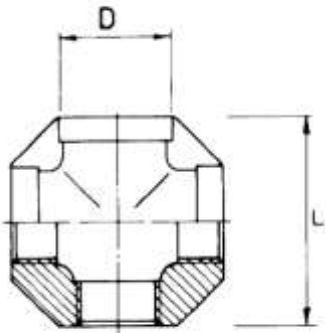

## Katalogové označení: 303

Koleno 45° závitové, 1.4401

Dimension inch	NW	L mm	D mm
1/8"	6	12,0	16,5
1/4"	8	14,0	20,0
3/8"	10	16,0	23,5
1/2"	15	20,0	28,0
3/4"	20	27,5	36,0
1"	25	32,5	45,0
1 1/4"	32	40,0	54,0
1 1/2"	40	46,5	59,0
2"	50	54,0	57,5
2 1/2"	65	61,5	90,0
3"	80	71,0	114,0
4"	100	88,5	135,0

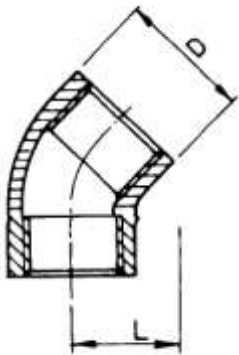

## Katalogové označení: 304

Koleno 90° závitové I/A, 1.4401

Dimension inch	NW	L mm	D mm
1/8"	6	18,0	16,0
1/4"	8	20,0	22,0
3/8"	10	22,0	22,7
1/2"	15	29,0	28,0
3/4"	20	31,0	34,0
1"	25	36,0	42,0
1 1/4"	32	43,9	51,3
1 1/2"	40	50,0	57,4
2"	50	60,3	70,0
2 1/2"	65	69,1	86,3
3"	80	77,6	101,0
4"	100	95,1	127,0

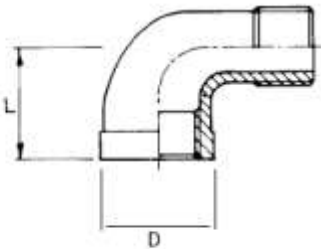

## Katalogové označení: 305

Trubkový ohyb 90° závitový A/A, 1.4571

Dimension inch	NW	L mm	D mm
1/8"	6	50,0	10,2
1/4"	8	60,0	13,5
3/8"	10	70,0	17,2
1/2"	15	80,0	21,3
3/4"	20	100,0	26,9
1"	25	120,0	33,7
1 1/4"	32	140,0	42,4
1 1/2"	40	160,0	48,3
2"	50	190,0	60,3
2 1/2"	65	240,0	76,1
3"	80	290,0	88,9

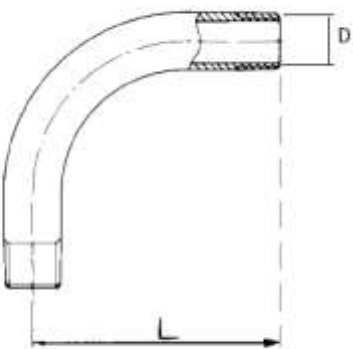

## Katalogové označení: 307

T-kus závitový, 1.4401

Dimension inch	NW	L mm	D mm
1/8"	6	34,0	14,0
1/4"	8	40,0	19,0
3/8"	10	47,0	23,0
1/2"	15	57,0	28,0
3/4"	20	62,5	32,0
1"	25	72,0	40,0
1 1/4"	32	89,0	52,0
1 1/2"	40	94,0	55,0
2"	50	111,0	67,0
2 1/2"	65	138,0	90,0
3"	80	155,0	96,0
4"	100	194,0	130,0

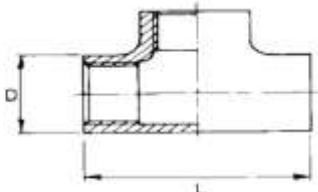

## Katalogové označení: 308

### Nippel přivařovací 1.4571

Dimension inch	NW	L mm	D mm
1/8"	6	30,0	10,2
1/4"	8	30,0	13,5
3/8"	10	30,0	17,2
1/2"	15	35,0	21,3
3/4"	20	40,0	26,9
1"	25	40,0	33,7
1 1/4"	32	50,0	42,4
1 1/2"	40	50,0	48,3
2"	50	50,0	60,3
2 1/2"	65	60,0	76,1
3"	80	70,0	88,9
4"	100	80,0	114,3

*Auch Sonderlängen sind vorrätig!*

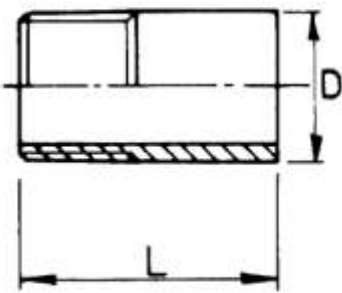

## Katalogové označení: 309

### Nippel celozávitový, 1.4401

Dimension inch	NW	L mm	D mm
1/8"	6	16,0	10,2
1/4"	8	18,0	13,5
3/8"	10	22,0	17,2
1/2"	15	25,0	21,3
3/4"	20	30,0	26,9
1"	25	35,0	33,7
1 1/4"	32	38,0	42,4
1 1/2"	40	38,0	48,3
2"	50	45,0	60,3
2 1/2"	65	55,0	76,1
3"	80	60,0	88,9
4"	100	70,0	114,3

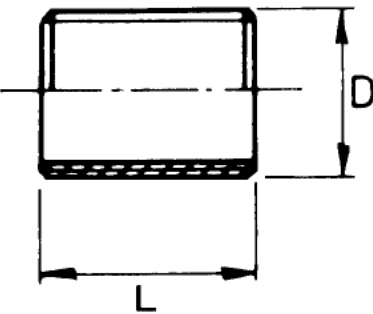



## Katalogové označení: 310

### Dvojnippel, 1.4401

Dimension inch	NW	L mm	D mm
1/8"	6	40,0	10,2
1/4"	8	40,0	13,5
3/8"	10	40,0	17,2
1/2"	15	60,0	21,3
3/4"	20	60,0	26,9
1"	25	60,0	33,7
1 1/4"	32	80,0	42,4
1 1/2"	40	80,0	48,3
2"	50	100,0	60,3
2 1/2"	65	100,0	76,1
3"	80	120,0	88,9
4"	100	120,0	114,3

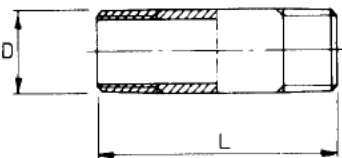
*Auch Sonderlängen sind vorrätig!*



## Katalogové označení: 311

Šroubení závitové s plochým těsněním, 1.4401

Dimension inch	NW	L mm	SW mm
1/8"	6	30,0	29,0
1/4"	8	30,0	29,0
3/8"	10	35,0	34,0
1/2"	15	40,0	39,0
3/4"	20	43,0	47,0
1"	25	48,0	58,0
1 1/4"	32	52,0	67,0
1 1/2"	40	58,0	76,0
2"	50	62,0	90,0
2 1/2"	65	71,0	108,0
3"	80	78,0	122,0
4"	100	85,0	152,0

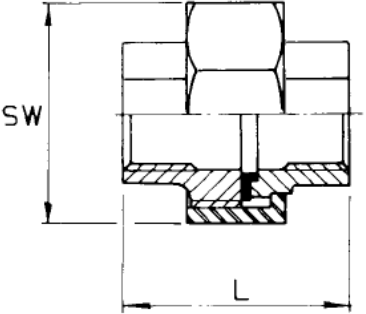

## Katalogové označení: 311W

Šroubení závitové s plochým těsněním a kolenem, 1.4401

Dimension inch	NW	L1 mm	L2 mm	SW mm
1/4"	8	40,7	18,0	29,0
3/8"	10	44,5	21,6	34,0
1/2"	15	50,0	26,0	38,5
3/4"	20	56,5	32,0	47,0
1"	25	65,0	40,0	58,0
1 1/4"	32	75,0	49,0	66,0
1 1/2"	40	81,5	55,8	75,0
2"	50	95,0	67,5	88,5

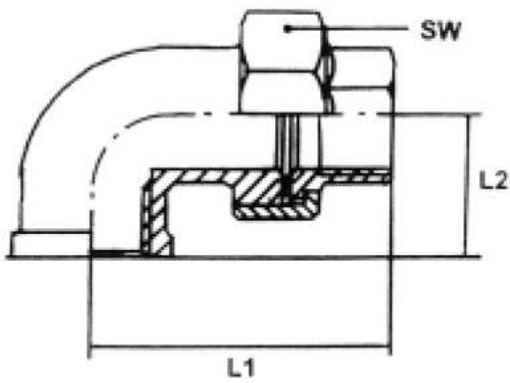

## Katalogové označení: 312

Šroubení s kónickou těsnící plochou, 1.4401

Dimension inch	NW	L mm	SW mm
1/8"	6	30,0	29,0
1/4"	8	30,0	29,0
3/8"	10	35,0	34,0
1/2"	15	40,0	39,0
3/4"	20	43,0	47,0
1"	25	48,0	58,0
1 1/4"	32	52,0	67,0
1 1/2"	40	58,0	76,0
2"	50	62,0	90,0
2 1/2"	65	71,0	108,0
3"	80	78,0	122,0
4"	100	85,0	152,0

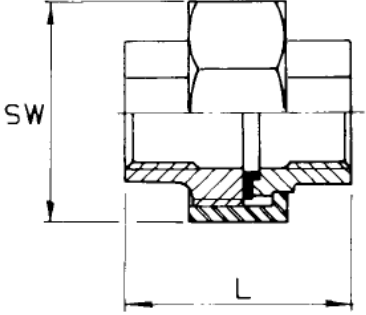

## Katalogové označení: 312W

Šroubení s kónickou těsnící plochou a kolenem, 1.4401

Dimension inch	NW	L1 mm	L2 mm	SW mm
1/4"	8	40,7	18,0	29,0
3/8"	10	44,5	21,6	34,0
1/2"	15	50,0	26,0	38,5
3/4"	20	56,5	32,0	47,0
1"	25	65,0	40,0	58,0
1 1/4"	32	75,0	49,0	66,0
1 1/2"	40	81,5	55,8	75,0
2"	50	95,0	67,5	88,5

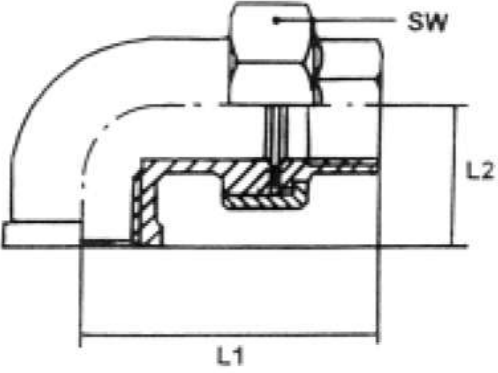

## Katalogové označení: 313

### Šroubení přivařovací s kónickou těsnící plochou, 1.4401

Dimension inch	NW	L mm	SW mm
1/8"	6	43,0	34,0
1/4"	8	43,0	34,0
3/8"	10	43,0	34,0
1/2"	15	46,0	38,0
3/4"	20	49,0	47,0
1"	25	55,0	54,0
1 1/4"	32	60,0	63,0
1 1/2"	40	64,0	70,0
2"	50	69,0	86,0
2 1/2"	65	89,0	108,0
3"	80	91,0	126,0
4"	100	107,0	144,0

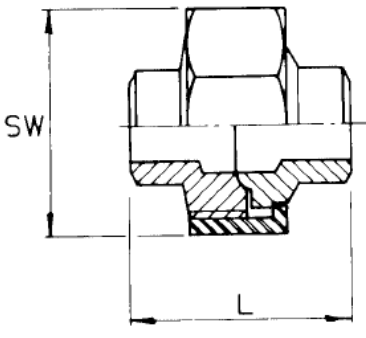

## Katalogové označení: 314

### Šroubení přivařovací s plochým těsněním, 1.4401

Dimension inch	NW	L mm	SW mm
1/8"	6	43,0	34,0
1/4"	8	43,0	34,0
3/8"	10	43,0	34,0
1/2"	15	46,0	38,0
3/4"	20	49,0	47,0
1"	25	55,0	54,0
1 1/4"	32	60,0	63,0
1 1/2"	40	64,0	70,0
2"	50	69,0	86,0
2 1/2"	65	89,0	108,0
3"	80	91,0	126,0
4"	100	107,0	144,0

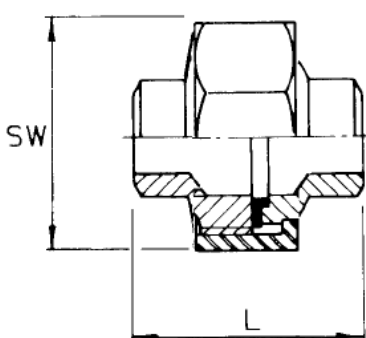

## Katalogové označení: 315

### Šroubení závitové I/A s kónickou těsnící plochou, 1.4401

Dimension inch	NW	L mm	SW mm
1/8"	6	42,0	29,0
1/4"	8	42,0	29,0
3/8"	10	51,0	34,0
1/2"	15	56,0	39,0
3/4"	20	61,0	47,0
1"	25	68,0	58,0
1 1/4"	32	76,0	67,0
1 1/2"	40	81,0	76,0
2"	50	90,0	90,0
2 1/2"	65	108,0	108,0
3"	80	114,0	122,0
4"	100	129,0	152,0

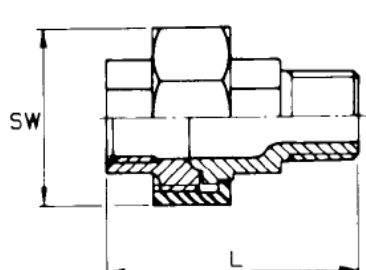

## Katalogové označení: 315W

Šroubení závitové I/A s kónickou těsnící plochou a kolenem, 1.4401

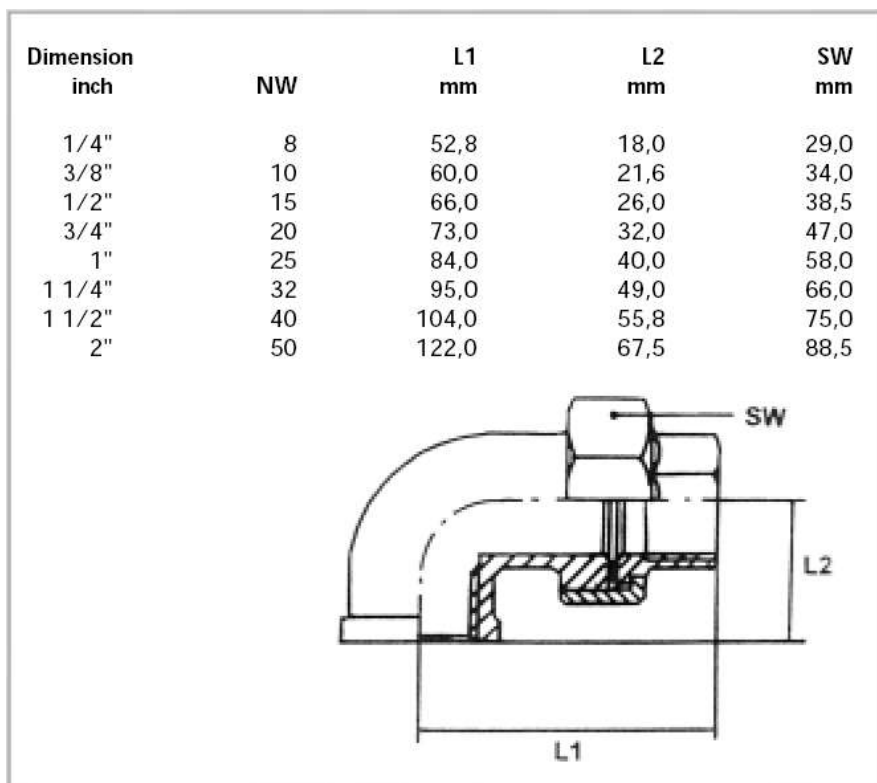

## Katalogové označení: 316

Šroubení závitové I/A s plochým těsněním, 1.4401

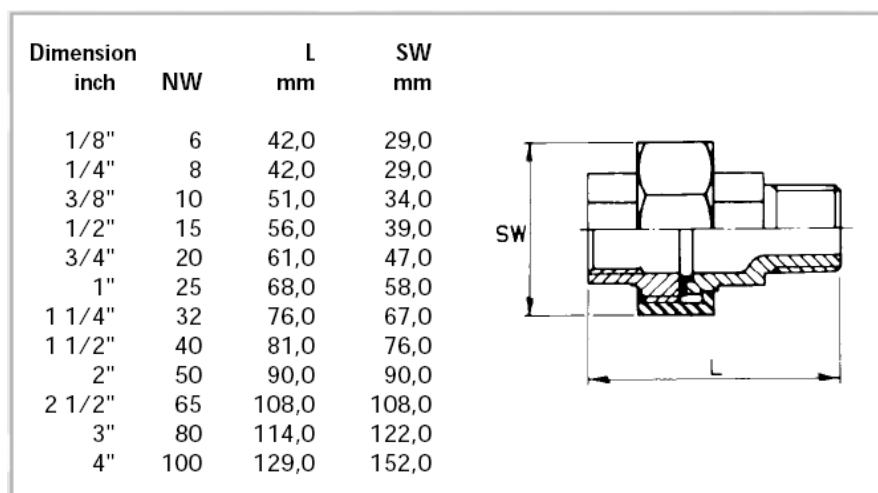

## Katalogové označení: 316W

Šroubení závitové I/A s plochým těsněním, 1.4401

Dimension inch	NW	L1 mm	L2 mm	SW mm
1/4"	8	52,8	18,0	29,0
3/8"	10	60,0	21,6	34,0
1/2"	15	66,0	26,0	38,5
3/4"	20	73,0	32,0	47,0
1"	25	84,0	40,0	58,0
1 1/4"	32	95,0	49,0	66,0
1 1/2"	40	104,0	55,8	75,0
2"	50	122,0	67,5	88,5

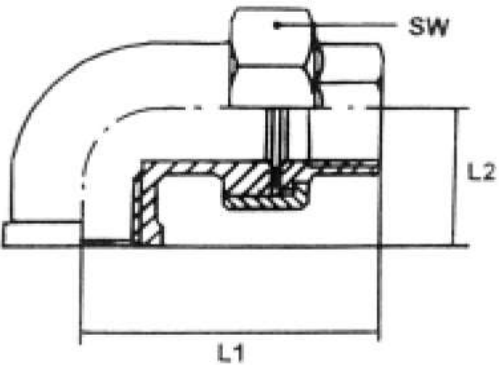

## Katalogové označení: 317

Šroubení závitové-privářovací A/S s plochým těsněním, 1.4401

Dimension inch	NW	L mm	SW mm
1/8"	6	48,0	29,0
1/4"	8	48,0	29,0
3/8"	10	56,0	34,0
1/2"	15	60,0	38,0
3/4"	20	66,0	47,0
1"	25	75,0	54,0
1 1/4"	32	80,0	63,0
1 1/2"	40	87,0	70,0
2"	50	96,0	86,0
2 1/2"	65	112,0	112,0
3"	80	125,0	126,0
4"	100	155,0	157,0

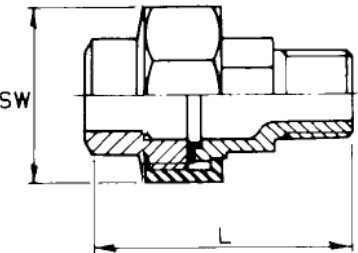





### Katalogové označení: 318

Šroubení přivařovací-závitové A/S s kónickou těsnící plochou, 4401

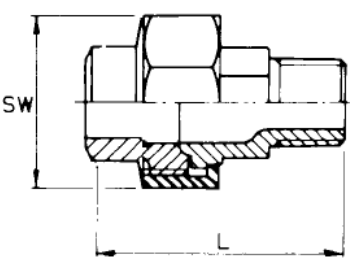
Dimension inch	NW	L mm	SW mm
1/8"	6	48,0	29,0
1/4"	8	48,0	29,0
3/8"	10	56,0	34,0
1/2"	15	60,0	38,0
3/4"	20	66,0	47,0
1"	25	75,0	54,0
1 1/4"	32	80,0	63,0
1 1/2"	40	87,0	70,0
2"	50	96,0	86,0
2 1/2"	65	112,0	112,0
3"	80	125,0	126,0
4"	100	155,0	157,0



### Katalogové označení: 319

Šroubení závitové-přivařovací I/S s plochým těsněním, 1.4401

Dimension inch	NW	L mm	SW mm
1/2"	15	44,0	38,0
3/4"	20	47,0	47,0
1"	25	54,0	53,0
1 1/4"	32	62,0	63,0
1 1/2"	40	64,0	70,0
2"	50	69,0	90,0

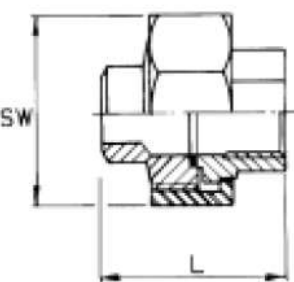

### Katalogové označení: 320

Šroubení závitové-přivařovací I/S s kónickou těsnící plochou, 1.4401

Dimension inch	NW	L mm	SW mm
1/2"	15	44,0	38,0
3/4"	20	47,0	47,0
1"	25	54,0	53,0
1 1/4"	32	62,0	63,0
1 1/2"	40	64,0	70,0
2"	50	69,0	90,0

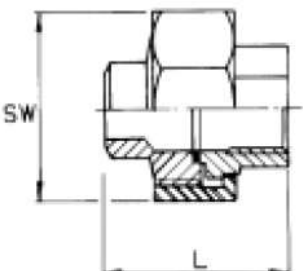

## Katalogové označení: 321

Šroubení závitové A/A s plochým těsněním, 1.4401

Dimension inch	NW	L mm	SW mm
1/2"	15	73,0	42,0
3/4"	20	82,0	47,0
1"	25	90,0	53,0
1 1/4"	32	104,0	71,0
1 1/2"	40	110,0	78,0
2"	50	118,0	92,0

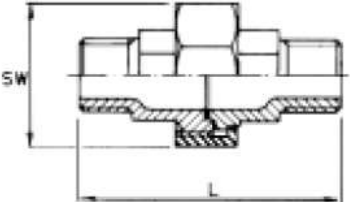

## Katalogové označení: 322

Šroubení závitové A/A s kónickou těsnící plochou, 1.4401

Dimension inch	NW	L mm	SW mm
1/2"	15	73,0	42,0
3/4"	20	82,0	47,0
1"	25	90,0	53,0
1 1/4"	32	104,0	71,0
1 1/2"	40	110,0	78,0
2"	50	118,0	92,0

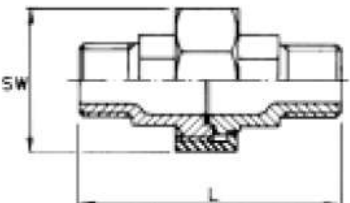

## Katalogové označení: 323

Šroubení závitové s hadicovým nástavcem a kónickou těsnící plochou, 1.4401

Dimension inch	NW	L mm	SW mm	D mm
3/8"	10	68,0	35,0	11,0
1/2"	15	80,0	42,0	12,7
3/4"	20	86,0	47,0	19,0
1"	25	91,0	53,0	25,4
1 1/4"	32	104,0	71,0	31,8
1 1/2"	40	119,0	77,0	38,1
2"	50	130,0	92,0	50,8

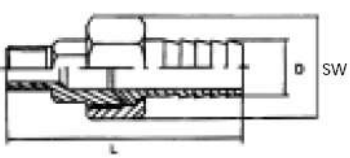

## Katalogové označení: 325

Šestihranné redukce, 1.4401

Dimension inch	x	inch	NW	x	NW	L	SW
						mm	mm
1/4"	x	1/8"	8	x	6	15,0	16,0
3/8"	x	1/8"	10	x	6	19,5	21,5
3/8"	x	1/4"	10	x	8	19,5	21,5
1/2"	x	1/8"	15	x	6	21,0	22,0
1/2"	x	1/4"	15	x	8	21,0	22,0
1/2"	x	3/8"	15	x	10	21,0	22,0
3/4"	x	1/4"	20	x	8	24,0	29,5
3/4"	x	3/8"	20	x	10	24,0	29,5
3/4"	x	1/2"	20	x	15	24,0	29,5
1"	x	1/4"	25	x	8	27,0	36,0
1"	x	3/8"	25	x	10	27,0	36,0
1"	x	1/2"	25	x	15	27,0	36,0
1"	x	3/4"	25	x	20	27,0	36,0
1 1/4"	x	3/8"	32	x	10	30,0	46,0
1 1/4"	x	1/2"	32	x	15	30,0	46,0
1 1/4"	x	3/4"	32	x	20	30,0	46,0
1 1/4"	x	1"	32	x	25	30,0	46,0
1 1/2"	x	1/2"	40	x	15	33,0	50,5
1 1/2"	x	3/4"	40	x	20	33,0	50,5
1 1/2"	x	1"	40	x	25	33,0	50,5
1 1/2"	x	1 1/4"	40	x	32	33,0	50,5
2"	x	1/2"	50	x	15	39,0	63,0
2"	x	3/4"	50	x	20	39,0	63,0
2"	x	1"	50	x	25	39,0	63,0
2"	x	1 1/4"	50	x	32	39,0	63,0
2"	x	1 1/2"	50	x	40	39,0	63,0
2 1/2"	x	1"	65	x	25	42,5	82,5
2 1/2"	x	1 1/4"	65	x	32	42,5	82,5
2 1/2"	x	1 1/2"	65	x	40	42,5	82,5
2 1/2"	x	2"	65	x	50	42,5	82,5
3"	x	1 1/2"	80	x	40	45,0	95,0
3"	x	2"	80	x	50	45,0	95,0
3"	x	2 1/2"	80	x	65	45,0	95,0
4"	x	2"	100	x	50	53,0	117,0
4"	x	2 1/2"	100	x	65	53,0	117,0
4"	x	3"	100	x	80	53,0	117,0



## Katalogové označení: 326

### Šestihranná zátka, 1.4401

Dimension inch	NW	L mm	SW mm
1/8"	6	17,5	18,0
1/4"	8	17,0	18,0
3/8"	10	18,0	21,0
1/2"	15	20,0	27,0
3/4"	20	21,5	32,0
1"	25	25,0	39,5
1 1/4"	32	28,0	49,0
1 1/2"	40	30,0	55,0
2"	50	36,5	67,5
2 1/2"	65	48,0	87,0
3"	80	52,5	100,0
4"	100	55,0	121,0

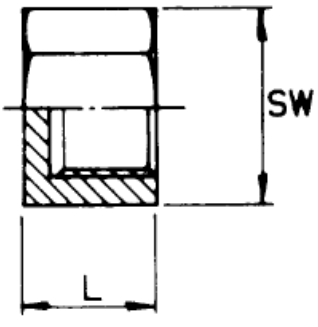

## Katalogové označení: 327

### Šestihranná matice, 1.4401

Dimension inch	NW	L mm	SW mm
1/8"	6	7,0	17,0
1/4"	8	7,5	19,0
3/8"	10	8,0	24,0
1/2"	15	8,5	30,0
3/4"	20	10,0	36,0
1"	25	10,5	41,0
1 1/4"	32	11,5	51,0
1 1/2"	40	12,5	60,0
2"	50	14,5	70,0
2 1/2"	65	18,0	90,5
3"	80	21,0	100,0
4"	100	21,5	150,0

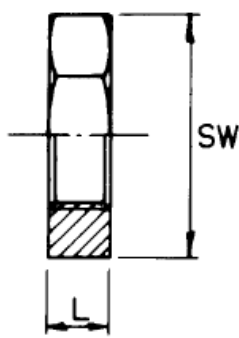

## Katalogové označení: 329

### Zátka s čtyřhranem, 1.4401

Dimension inch	NW	L mm	SW mm
1/8"	6	19,5	7,0
1/4"	8	16,5	9,0
3/8"	10	18,0	10,0
1/2"	15	21,0	14,0
3/4"	20	24,5	17,0
1"	25	27,5	19,0
1 1/4"	32	35,0	23,0
1 1/2"	40	35,0	26,5
2"	50	42,5	32,5
2 1/2"	65	46,0	39,5
3"	80	50,0	39,5
4"	100	59,0	58,0

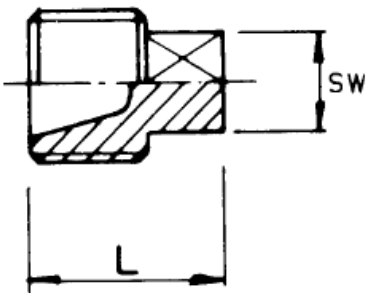

**Katalogové označení: 330**

Šestihránná zátka vnější závit, 1.4401

Dimension inch	NW	L mm	SW mm
1/8"	6	17,0	16,5
1/4"	8	17,0	16,5
3/8"	10	18,5	21,5
1/2"	15	21,0	25,5
3/4"	20	24,0	32,0
1"	25	27,5	38,0
1 1/4"	32	30,0	46,0
1 1/2"	40	30,0	52,0
2"	50	33,0	62,5
2 1/2"	65	40,0	81,0
3"	80	41,0	94,0
4"	100	47,0	116,5

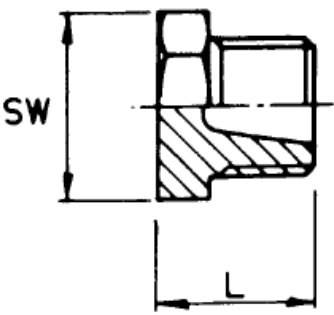
**Katalogové označení: 331**

Šestihránná zátka dle DIN 910, 1.4401

Dimension inch	NW	L mm	SW mm
1/8"	6	17,0	10,0
1/4"	8	17,0	13,0
3/8"	10	17,0	17,0
1/2"	15	22,0	19,0
3/4"	20	26,0	24,0
1"	25	32,0	27,0
1 1/4"	32	33,0	30,0
1 1/2"	40	33,0	34,0
2"	50	40,0	36,0

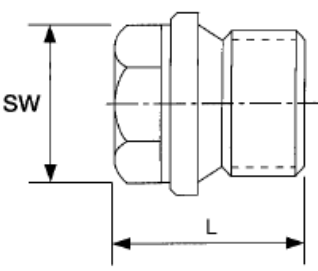
**Katalogové označení: 333**

Mufna, 1.4401

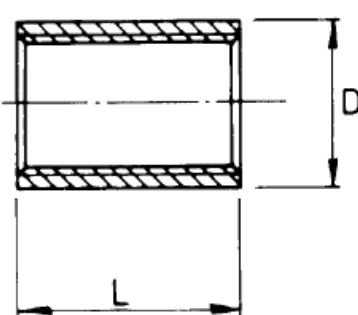

Dimension inch	NW	L mm	D mm
1/8"	6	17,0	14,0
1/4"	8	25,0	17,5
3/8"	10	26,0	21,3
1/2"	15	34,0	26,4
3/4"	20	36,0	31,8
1"	25	43,0	39,5
1 1/4"	32	48,0	48,3
1 1/2"	40	48,0	54,5
2"	50	56,0	66,3
2 1/2"	65	65,0	82,0
3"	80	71,0	95,0
4"	100	83,0	122,0



## Katalogové označení: 334

### Poloviční mufna, 1.4401

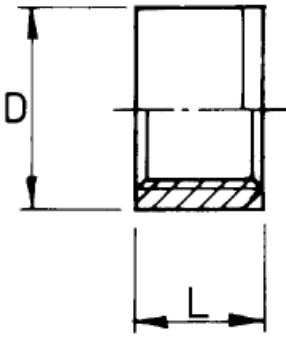
Dimension inch	NW	L mm	D mm
1/8"	6	7,5	14,0
1/4"	8	11,0	17,5
3/8"	10	11,5	21,3
1/2"	15	15,0	26,4
3/4"	20	16,5	31,8
1"	25	19,0	39,5
1 1/4"	32	22,0	48,3
1 1/2"	40	22,0	54,5
2"	50	26,0	66,3
2 1/2"	65	30,0	82,0
3"	80	33,0	95,0
4"	100	39,0	122,0

## Katalogové označení: 335

### Mufna redukovávaná, 1.4401

Dimension inch	x	inch	NW	x	NW	L mm	Dimension inch	x	inch	NW	x	NW	L mm
1/4"	x	1/8"	8	x	6	26,0	1 1/2"	x	1/2"	40	x	15	51,5
3/8"	x	1/8"	10	x	6	28,0	1 1/2"	x	3/4"	40	x	20	51,5
3/8"	x	1/4"	10	x	8	28,0	1 1/2"	x	1"	40	x	25	51,5
1/2"	x	1/8"	15	x	6	34,0	1 1/2"	x	1 1/4"	40	x	32	51,5
1/2"	x	1/4"	15	x	8	34,0	2"	x	1"	50	x	15	57,0
1/2"	x	3/8"	15	x	10	34,0	2"	x	1 1/4"	50	x	20	57,0
3/4"	x	1/4"	20	x	8	37,0	2"	x	1 1/2"	50	x	25	57,0
3/4"	x	3/8"	20	x	10	37,0	2"	x	1 1/2"	50	x	32	57,0
3/4"	x	1/2"	20	x	15	37,0	2 1/2"	x	1 1/4"	65	x	32	65,0
1"	x	3/8"	25	x	8	40,0	2 1/2"	x	1 1/2"	65	x	40	65,0
1"	x	1/2"	25	x	10	40,0	2 1/2"	x	2"	65	x	50	65,0
1"	x	3/4"	25	x	15	40,0	3"	x	2"	80	x	50	71,0
1"	x	3/4"	25	x	20	40,0	3"	x	2 1/2"	80	x	65	71,0
1 1/4"	x	1/2"	32	x	15	48,0	4"	x	2"	100	x	50	84,0
1 1/4"	x	3/4"	32	x	20	48,0	4"	x	2 1/2"	100	x	65	84,0
1 1/4"	x	1"	32	x	25	53,0	4"	x	3"	100	x	80	84,0

## Katalogové označení: 337

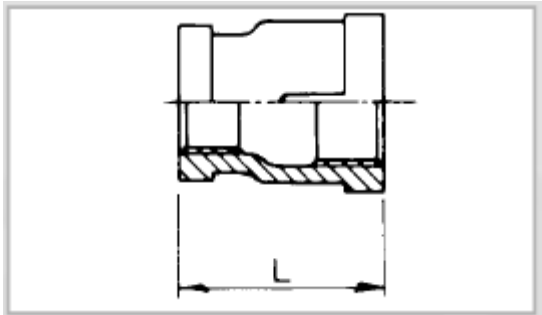
### Hadicový nippel, 1.4401

Dimension inch	NW	L mm	D mm
1/8"	6	35,0	7,0
1/4"	8	47,0	9,0
3/8"	10	51,0	11,0
1/2"	15	63,0	12,7
3/4"	20	66,5	20,0
1"	25	71,0	25,4
1 1/4"	32	77,5	33,0
1 1/2"	40	90,0	39,0
2"	50	96,5	51,0
2 1/2"	65	120,0	65,0
3"	80	128,0	77,5
4"	100	140,0	103,0

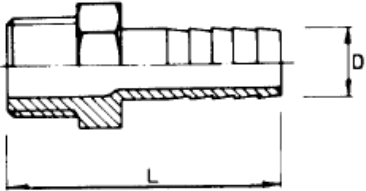

## Katalogové označení: 337S

### Přivařovací hadicový nippel, 1.4401

Dimension inch	NW	D mm	L mm
1/4"	8	13,5	70,0
3/8"	10	17,2	70,0
1/2"	15	21,3	70,0
3/4"	20	26,9	70,0
1"	25	33,7	70,0
1 1/4"	32	42,4	70,0
1 1/2"	40	48,3	100,0
2"	50	60,3	100,0

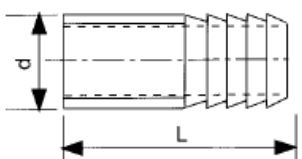

## Katalogové označení: 337G

### Závitový hadicový nippel, 1.4401

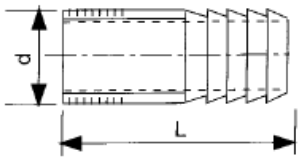

Dimension inch	NW	D mm	L mm
1/4"	8	13,5	70,0
3/8"	10	17,2	70,0
1/2"	15	21,3	70,0
3/4"	20	26,9	70,0
1"	25	33,7	70,0
1 1/4"	32	42,4	70,0
1 1/2"	40	48,3	100,0
2"	50	60,3	100,0



## Katalogové označení: 340

### Dvojité nippel s šestihranem, 1.4401

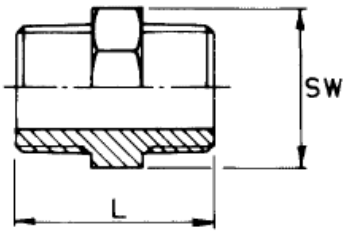
Dimension inch	NW	L mm	SW mm
1/8"	6	26,0	12,0
1/4"	8	28,0	15,0
3/8"	10	30,0	18,0
1/2"	15	36,0	22,0
3/4"	20	41,0	28,0
1"	25	46,0	36,0
1 1/4"	32	52,0	44,0
1 1/2"	40	54,0	50,0
2"	50	63,0	64,0
2 1/2"	65	71,0	80,0
3"	80	83,0	90,0
4"	100	96,0	117,0

## Katalogové označení: 341

### Dvojité redukovaný nippel s šestihranem, 1.4401

Dimension inch	x	inch	NW	x	NW	L mm	SW mm	Dimension inch	x	inch	NW	x	NW	L mm	SW mm
1/4"	x	1/8"	8	x	6	32,0	15,0	1 1/2"	x	1/2"	40	x	15	54,0	50,0
								1 1/2"	x	3/4"	40	x	20	54,0	50,0
3/8"	x	1/8"	10	x	6	34,0	21,0	1 1/2"	x	1"	40	x	25	54,0	50,0
3/8"	x	1/4"	10	x	8	34,0	21,0	1 1/2"	x	1 1/4"	40	x	32	58,0	50,0
1/2"	x	1/8"	15	x	6	40,0	23,0	2"	x	1/2"	50	x	15	59,0	63,0
1/2"	x	1/4"	15	x	8	40,0	23,0	2"	x	3/4"	50	x	20	59,0	63,0
1/2"	x	3/8"	15	x	10	40,0	23,0	2"	x	1"	50	x	25	59,0	63,0
3/4"	x	1/4"	20	x	8	46,0	29,0	2"	x	1 1/4"	50	x	32	61,0	63,0
3/4"	x	3/8"	20	x	10	46,0	29,0	2"	x	1 1/2"	50	x	40	61,0	63,0
3/4"	x	1/2"	20	x	15	46,0	29,0	2 1/2"	x	1 1/4"	65	x	32	71,0	77,0
1"	x	1/4"	25	x	8	47,0	35,0	2 1/2"	x	1 1/2"	65	x	40	71,0	77,0
1"	x	3/8"	25	x	10	47,0	35,0	2 1/2"	x	2"	65	x	50	76,0	77,0
1"	x	1/2"	25	x	15	47,0	35,0	3"	x	2"	80	x	50	80,0	92,0
1"	x	3/4"	25	x	20	47,0	35,0	3"	x	2 1/2"	80	x	65	85,0	92,0
1 1/4"	x	1/2"	32	x	15	51,0	46,0	4"	x	2"	100	x	50	85,0	118,0
1 1/4"	x	3/4"	32	x	20	51,0	46,0	4"	x	2 1/2"	100	x	65	85,0	118,0
1 1/4"	x	1"	32	x	25	51,0	46,0	4"	x	3"	100	x	80	85,0	118,0



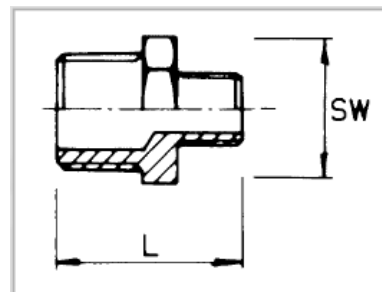

## Katalogové označení: 300

Kulový ventil jednodílný, redukováný průtok, 1.4408, závitů DIN 259/2999,  
pracovní tlak = 55 bar, atest dle EN 10204-3.1B

Dodání: skladem



Díly	Materiál
1) Vnější tělo	1.4408
2) Vnitřní matice	1.4408
3) Kloule	1.4408
4) Sedlo	PTFE 15%
5) Těsnění tělesa	PTFE
6) Hřídel	1.4401
7) Těsnící kroužek	PTFE
8) Ucpávka hřídele	PTFE
9) Podložka	1.4301
10) Páka	1.4301
11) Pérová podložka	1.4301
12) Matice	1.4301
13) Potah páky	Plast
14) Aretace (volitelná)	1.4301

### Pressure - Temperature Rating V-1 Type 1/4" - 2"

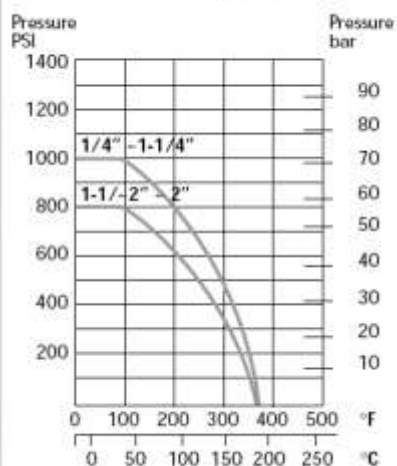

Kulový kohout 1-dílný,  
redukováný průtok,  
závitů DIN 259/2999,  
pracovní tlak = 55 bar

ball valve 1-piece,  
reduce bore,  
threaded DIN 259/299,  
working pressure = 800 Psi

DN Dim.	d mm	L mm	L1 mm	H mm	W mm	S mm	Cv Faktor	Torque kgf-cm	kgs
1/4"	5,0	39,0	19,0	35,0	66,0	17,0	3,8	12	0,070
3/8"	7,0	44,0	21,0	36,0	74,0	21,0	4,0	12	0,102
1/2"	9,2	56,5	27,5	41,0	89,0	25,0	4,5	13	0,166
3/4"	12,5	59,0	30,0	44,0	89,0	32,0	9,0	20	0,247
1"	16,0	71,0	36,0	51,0	105,0	38,0	16,0	38	0,412
1 1/4"	20,0	78,0	39,0	56,0	105,0	48,0	24,0	50	0,627
1 1/2"	24,5	83,0	41,7	64,0	130,0	53,0	37,0	72	0,838
2"	32,0	100,0	50,0	71,0	130,0	65,0	68,0	90	1,384

## Katalogové označení: 300 F

Kulový ventil dvoudílný, plný průtok, 1.4408, závity DIN 259/2999,  
pracovní tlak = 63/100 bar, atest dle EN 10204-3.1B

Dodání: skladem

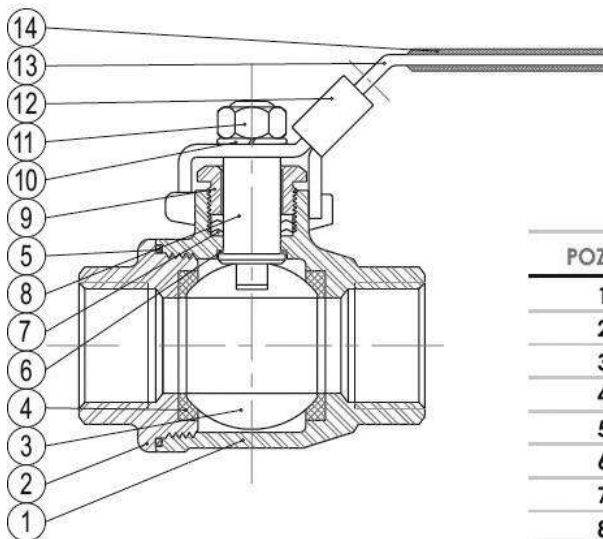
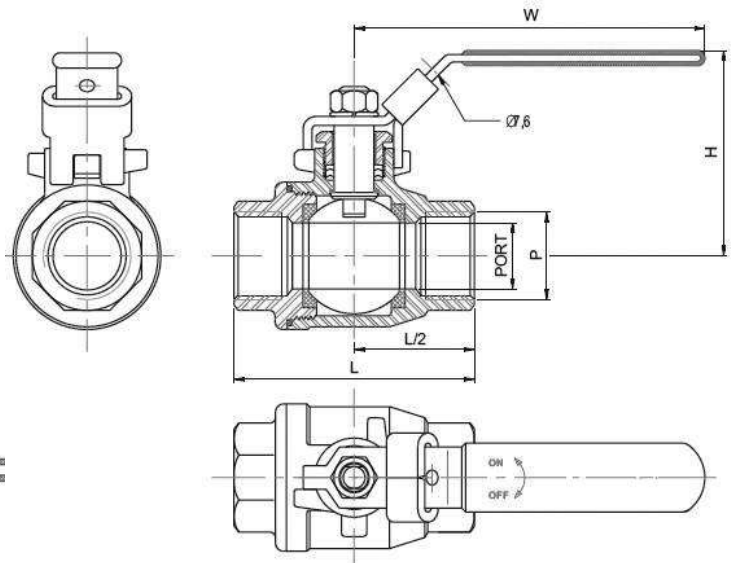

POZICE	NÁZEV	POČET	MATERIÁL
1	těleso	1	1.4408
2	víko tělesa	1	1.4408
3	koule	1	1.4408
4	sedlo	2	PTFE
5	těsnění tělesa	1	PTFE
6	těsnění hřídele	1	PTFE
7	ucpávka hřídele	1	PTFE
8	hřídel	1	1.4401
9	těsnící matice	1	1.4301
10	podložka	1	1.4301
11	matice	1	1.4301
12	aretace (volitelná)	1	1.4301
13	páka	1	1.4301
14	potah páky	1	plast

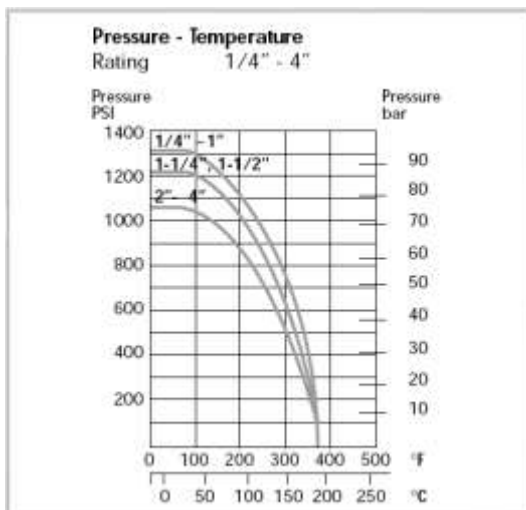

VELIKOST	PORT±0,1	L±2,0	H	W	P	m [Kg]
DN 8-¼"	11,6	55	50	100	DIN2999 1/4"	0,23
DN 10-¾"	12,5	55	50	100	DIN2999 3/8"	0,23
DN 15-½"	15	65	60	130	DIN2999 1/2"	0,28
DN 20-¾"	20	72	64	130	DIN2999 3/4"	0,44
DN 25-1"	25	84	71	165	DIN2999 1"	0,68
DN 32-1¼"	32	94	78	165	DIN2999 1-1/4"	1,06
DN 40-1½"	38	110	86	190	DIN2999 1-1/2"	1,62
DN 50-2"	50	126	95	190	DIN2999 2"	2,52

## Katalogové označení: 352 G

Kulový ventil třídný, plný průtok, 1.4408, závit DIN 259/2999,  
pracovní tlak = 63/100 bar, atest dle EN 10204-3.1B  
Dodání: skladem

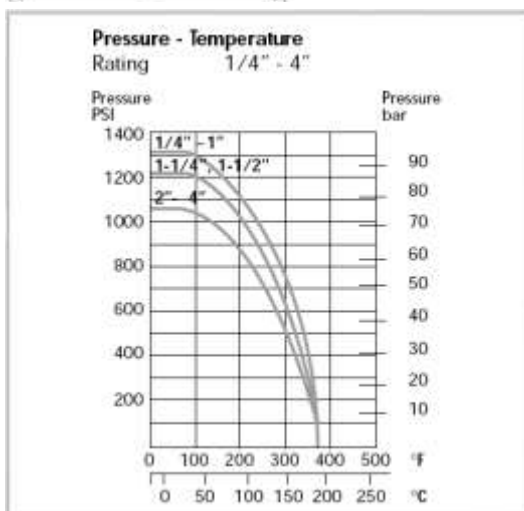
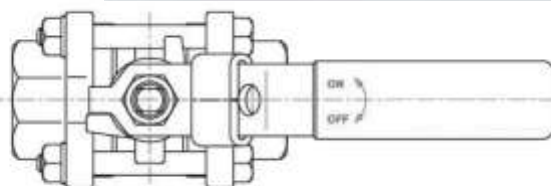
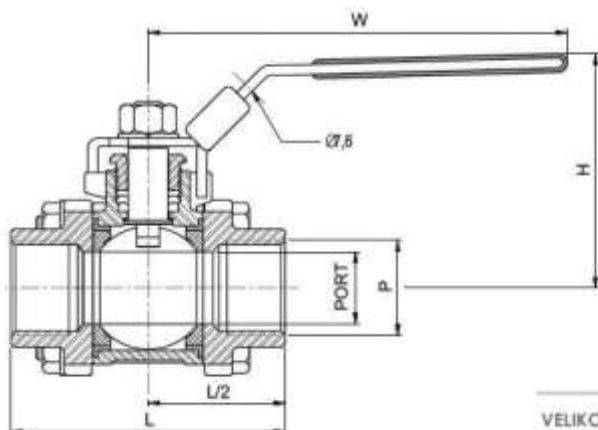

VELIKOST	PORT±0,1	L±2,0	H	W	P	m [Kg]
DN 8-¼"	11,2	57	50	100	DIN2999 1/4"	0,32
DN 10-¾"	12,5	57	50	100	DIN2999 3/8"	0,35
DN 15-½"	15	66	60	130	DIN2999 1/2"	0,52
DN 20-¾"	20	76	64	130	DIN2999 3/4"	0,72
DN 25-1"	25	86	71	165	DIN2999 1"	1,02
DN 32-1¼"	32	102	78	165	DIN2999 1-1/4"	1,68
DN 40-1½"	38	119	86	190	DIN2999 1-1/2"	2,32
DN 50-2"	50	131	95	190	DIN2999 2"	3,46
DN 65-2½"	56	165	132	250	DIN2999 2-1/2"	7,52
DN 80-3"	80	180	142	250	DIN2999 3"	10,8
DN 100-4"	100	240	175	290	DIN2999 4"	19,5

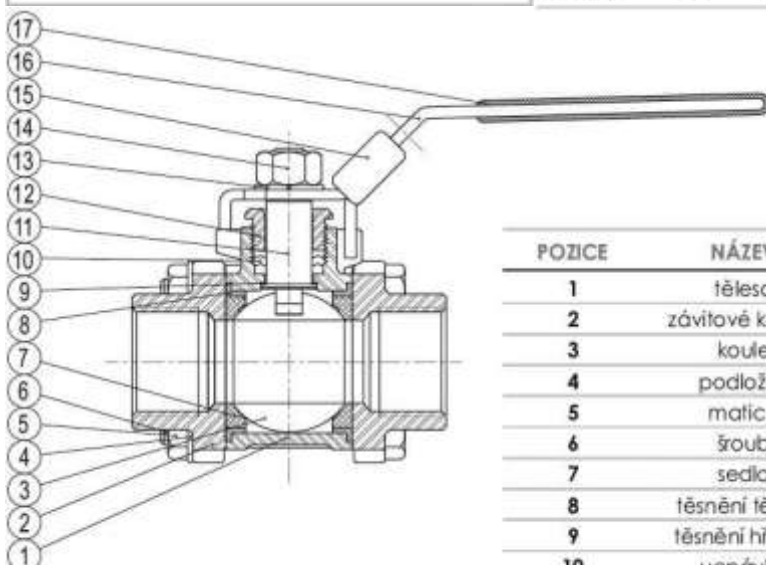

POZICE	NÁZEV	POČET	MATERIÁL
1	těleso	1	1.4408
2	závitové konce	2	1.4408
3	koule	1	1.4408
4	podložka	4	1.4301
5	matice	4	1.4301
6	šroub	4	1.4301
7	sedlo	2	PTFE
8	těsnění tělesa	2	PTFE
9	těsnění hřídele	1	PTFE
10	ucpávka	1	PTFE
11	hřídel	1	1.4401
12	těsnicí matice	1	1.4301
13	podložka	1	1.4301
14	matice	1	1.4301
15	areface (volitelná)	1	1.4301
16	páka	1	1.4301
17	potah páky	1	plast

## Katalogové označení: 352 S

Kulový ventil třídný, plný průtok, 1.4408, přivař,  
pracovní tlak = 63/100 bar, atest dle EN 10204-3.1  
Dodání: skladem

3,

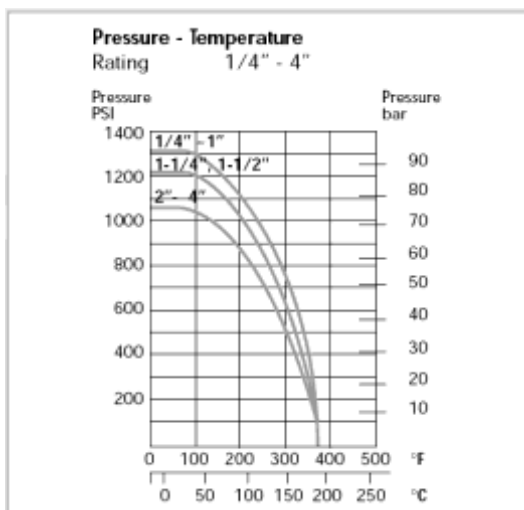
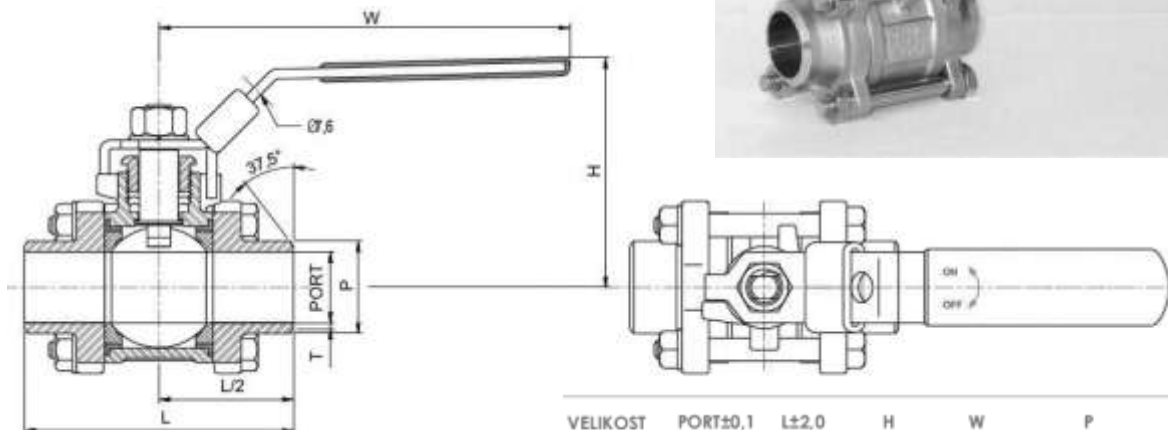

VELIKOST	PORT±0,1	L±2,0	H	W	P	m [Kg]
DN 8-1/4"	11,2	57	50	100	DIN2999 1/4"	0,32
DN 10-3/8"	12,5	57	50	100	DIN2999 3/8"	0,35
DN 15-1/2"	15	66	60	130	DIN2999 1/2"	0,52
DN 20-3/4"	20	76	64	130	DIN2999 3/4"	0,72
DN 25-1"	25	86	71	165	DIN2999 1"	1,02
DN 32-1 1/4"	32	102	78	165	DIN2999 1-1/4"	1,68
DN 40-1 1/2"	38	119	86	190	DIN2999 1-1/2"	2,32
DN 50-2"	50	131	95	190	DIN2999 2"	3,46
DN 65-2 1/2"	56	165	132	250	DIN2999 2-1/2"	7,52
DN 80-3"	80	180	142	250	DIN2999 3"	10,8
DN 100-4"	100	240	175	290	DIN2999 4"	19,5

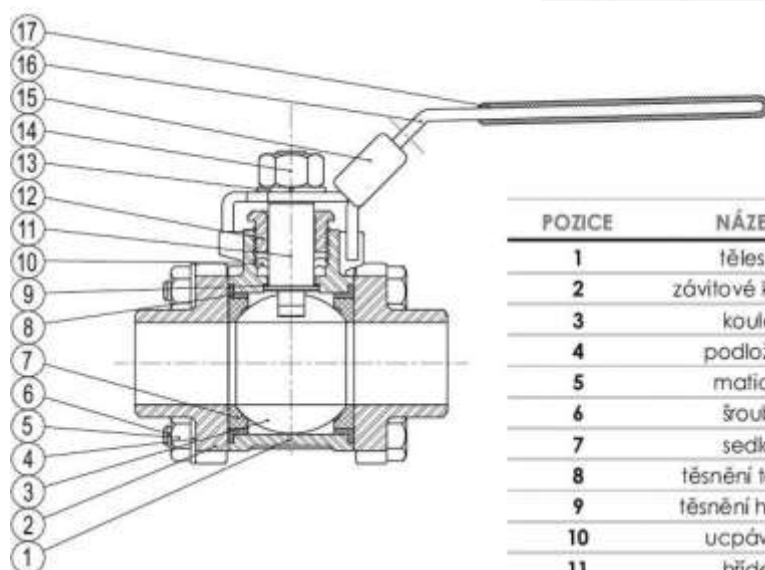

POZICE	NÁZEV	POČET	MATERIÁL
1	těleso	1	1.4408
2	závitové konce	2	1.4408
3	koule	1	1.4408
4	podložka	4	1.4301
5	matice	4	1.4301
6	šroub	4	1.4301
7	sedlo	2	PTFE
8	těsnění tělesa	2	PTFE
9	těsnění hřídele	1	PTFE
10	ucpávka	1	PTFE
11	hřídel	1	1.4401
12	těsnicí matice	1	1.4301
13	podložka	1	1.4301
14	matice	1	1.4301
15	zámek páky (na vyžádání)	1	1.4301
16	páka	1	1.4301
17	potah páky	1	plast

## Katalogové označení: 359

Jehlový ventil, 1.4408, závitů DIN 259/2999, pracovní tlak = 6000 PSI

Dodání: Na objednávku

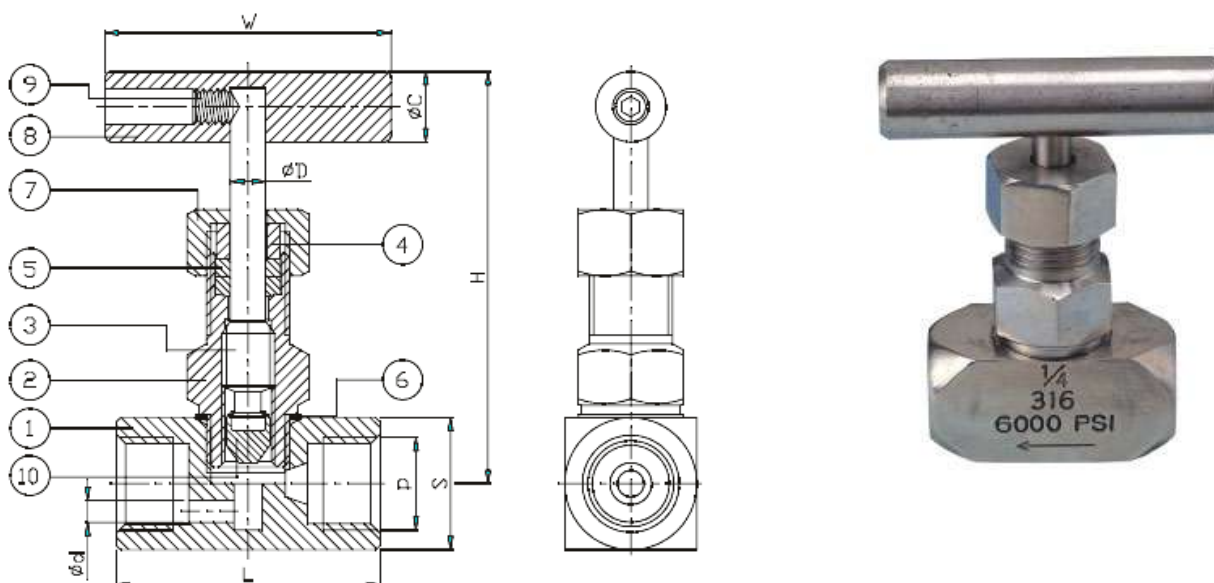

POZICE	NÁZEV	MATERIÁL
1	těleso	1.4408
2	pouzdro	1.4408
3	hřídel	1.4408
4	podložka	1.4408
5	ucpávka	PTFE
6	těsnění	PTFE
7	těsnicí matice	1.4408
8	páka	AISI 410
9	pojistný šroub	Nerez
10	disk	1.4408

Velikost	L	H	H1	W	d	D	S	C	G	P	m [kg]
DN 4 - 1/8"	45	70	82	60	3	7	22	13	21	1/8"	0.27
DN 8 - 1/4"	45	70	82	60	3	7	22	13	21	1/4"	0.27
DN 10 - 3/8"	50	72	85.4	60	3	7	25	13	21	3/8"	0.32
DN 15 - 1/2"	60	86	106.4	65	4	8	30	16	24	1/2"	0.53
DN 20 - 3/4"	65	92	111	65	5	8	35	16	24	3/4"	0.66
DN 25 - 1"	83	112	135	80	7	10	46	19	30	1"	1.40

## Katalogové označení: 353 L / 353 T

Kulový ventil dvoudílný třicestný, vrtání koule „L“ nebo „T“, plný průtok, 1.4408, závitů DIN 259/2999, pracovní tlak = 63/100 bar, atest dle EN 10204-3.1B

Dodání: Na objednávku

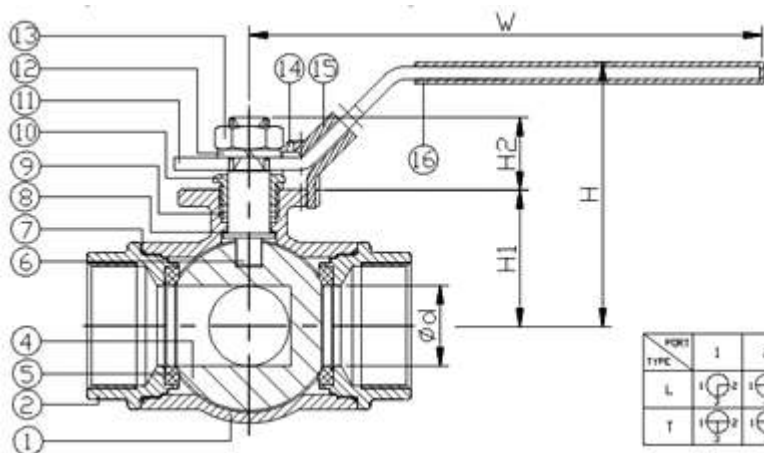

PORT TYPE	1	2	3	4
L				
T				

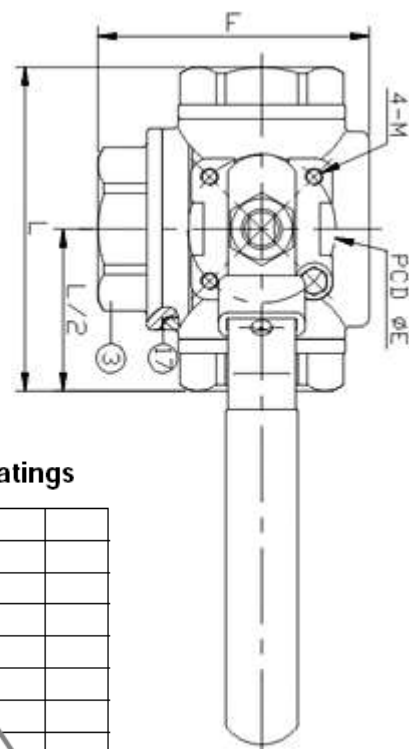

POZICE	NÁZEV	MATERIÁL
1	těleso	1.4408
2	závitové víko	1.4408
3	závitové víko	1.4408
4	koule	1.4408
5	sedlo	PTFE
6	hřídel	1.4408
7	těsnění tělesa	PTFE
8	opěrná podložka	PTFE
9	ucpávka hřídele	PTFE
10	těsnící matice	1.4301
11	páka	1.4301
12	podložka	1.4301
13	matice	1.4301
14	čep	1.4301
15	aretace	1.4301
16	potah páky	plast
17	těsnění tělesa	PTFE

### Pressure temperature ratings

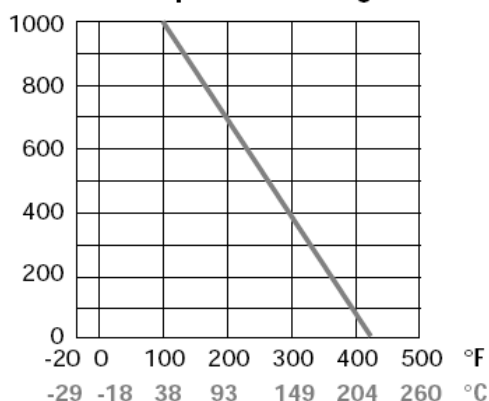

Velikost	d	L	F	H	W	E	M	H 1	H 2
DN 8 - 1/4"	11,6	76	58,5	67	150	42	M 5	29,1	18,3
DN 10 - 3/8"	12,5	76	58,5	67	150	42	M 5	29,1	18,3
DN 15 - 1/2"	12,5	76	58,5	67	150	42	M 5	29,1	18,3
DN 20 - 3/4"	16	86	72,1	77	150	42	M 5	38,5	20,3
DN 25 - 1"	20	99,1	81,8	83	180	50	M 6	43	23,2
DN 32 - 1 1/4"	25	117,4	94,7	88	180	50	M 6	47,8	23,2
DN 40 - 1 1/2"	32	123,8	103,9	116	243,5	70	M 8	55,7	34,2
DN 50 - 2"	38	148	125,5	124	243,5	70	M 8	64,5	34,2